



SINGLE FAMILY BASEMENT FINISH

The purpose of this checklist is to assist you in the submittal and permit process for your project. This checklist is intended as a basic plan submittal guideline under the 2021 International Building Code. It is not intended to cover all circumstances. Depending on the scope and complexity of your project, additional and/or more detailed plans may be required.

HOW TO USE THIS GUIDE

SUBMIT A COMPLETED PERMIT APPLICATION

Applications may be submitted on the City of Centennial website by clicking [HERE](#). It is important that the permit/application is filled out completely to the best of your knowledge and that you provide any additional pertinent information (i.e., owner and contractor contact information). Fill in the blanks within this guide and indicate which construction materials will be used. It is important to print legibly to help staff review the submitted information. In most cases, the information provided within this worksheet will satisfy the requirement for a complete submittal.

PROVIDE A FLOOR PLAN

1. Show the existing dimensions of the basement and provide dimensions of all new rooms, any new openings and items to be relocated (an example is provided within this guide).
 - a. A plan or letter from a registered engineer is required when any new openings in the existing foundation wall or in a bearing wall are proposed to ensure structural integrity has not been compromised.
 - b. List window dimensions and type of windows being installed. Clearly identify emergency escape/rescue windows and size of window wells.
 - c. All basements and bedrooms require emergency egress windows and where the emergency egress is below grade, a code compliant window well w/ladder shall be provided (see requirements shown in this guide). Emergency egress windows cannot be enclosed or obstructed in any way. Egress windows located under a deck must have a clear path of egress at least 36 inches in height that leads directly to the exterior of the home.
 - d. Habitable rooms shall comply with the requirements for natural light and ventilation shown in the table below. When the requirements for light and ventilation cannot be met by natural means, a whole house ventilation system shall be provided in accordance with section M1507 of the 2015 International Residential Code.
 - e. A smoke detector is required in every basement and bedroom. New smoke detectors installed as part of a basement finish shall be interconnected so that if one alarm is activated, this will activate all of the alarms within the new space. The new devices do not have to be physically interconnected if using listed wireless smoke detectors.
 - f. Provide detail regarding plumbing modifications and show furnace and water heater locations.
 - g. Modifications to existing posts, beams, and joists must be shown (a plan or letter from a registered engineer may be required).
 - h. Clearly indicate areas where ceiling heights are less than 7'.

SINGLE FAMILY BASEMENT FINISH

ROOM PLANNING REQUIREMENTS (R303 through R305)

Use	Area (ft ²)	Width	Ceiling height†	Natural light*	Natural ventilation*
Living	70	7'-0"	7'-0"	8% floor area	4% floor area
Dining	70	7'-0"	7'-0"	8% floor area	4% floor area
Kitchen	N.A.	N.A.	7'-0"	8% floor area	4% floor area
Bedroom	70	7'-0"	7'-0"	8% floor area	4% floor area
Bathroom	N.A.	N.A.	6'-8"	3 square feet	1½ square feet

* See Sections R303.1 & R303.3 for mechanical ventilation and artificial light and R303.4 for required whole-house mechanical ventilation.

† 6'-8" min. at plumbing fixtures and for non-habitable basements.

ADDITIONAL REQUIREMENTS

1. Homes with automatic fire suppression systems (fire sprinklers) require suppression plans to be submitted, reviewed, and approved by South Metro Fire Rescue. Please click [HERE](#) to learn more about submittal requirements for South Metro Fire Rescue.
2. If your home is served by a septic system, an approval letter from Tri-County Health Department is required if you are adding bedroom(s) in the basement. Click [HERE](#) for more information.

NOTE: If documents are submitted that do not encompass all of the requirements outlined above, the submittal will be deemed an incomplete project submittal and will not be reviewed until such time all required information has been provided.

FLOOR PLAN EXAMPLE

Smoke alarms and carbon monoxide alarms are required.

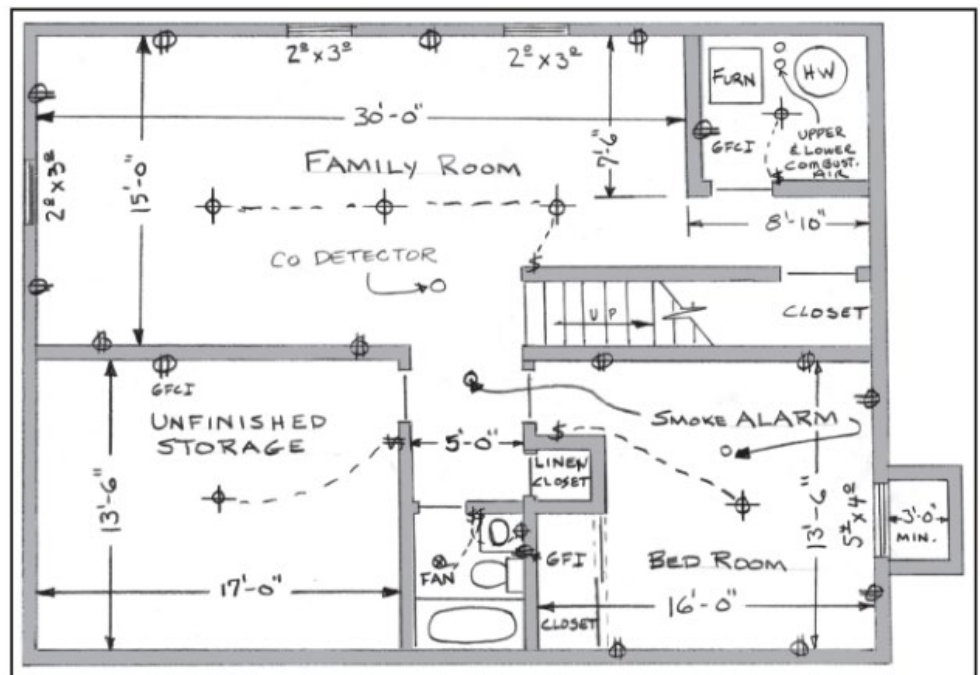



Centennial

C O L O R A D O

SINGLE FAMILY BASEMENT FINISH

EMERGENCY EGRESS REQUIREMENTS

Emergency Escape & Rescue Window Well

Emergency Escape And Rescue window wells must provide a minimum area of 9 square feet with a minimum dimension of 36 inches and shall enable the window to open fully. If the depth of the window well exceeds 44 inches, a permanently affixed ladder must be provided. The ladder must not interfere with the operation of the window.

Emergency Escape & Rescue Window

Emergency Escape And Rescue Windows must meet the following criteria:

- A minimum total openable area of not less than 5.7 square feet
- A minimum clear openable height of not less than 24 inches
- A minimum clear openable width of not less than 20 inches.
- A finished sill height of not more than 44 inches above the floor and the window should be openable from the inside with normal operation and without the use of tools, keys or special knowledge.

Examples of Complying Height & Width Combinations

FIXTURE CLEARANCE REQUIREMENTS

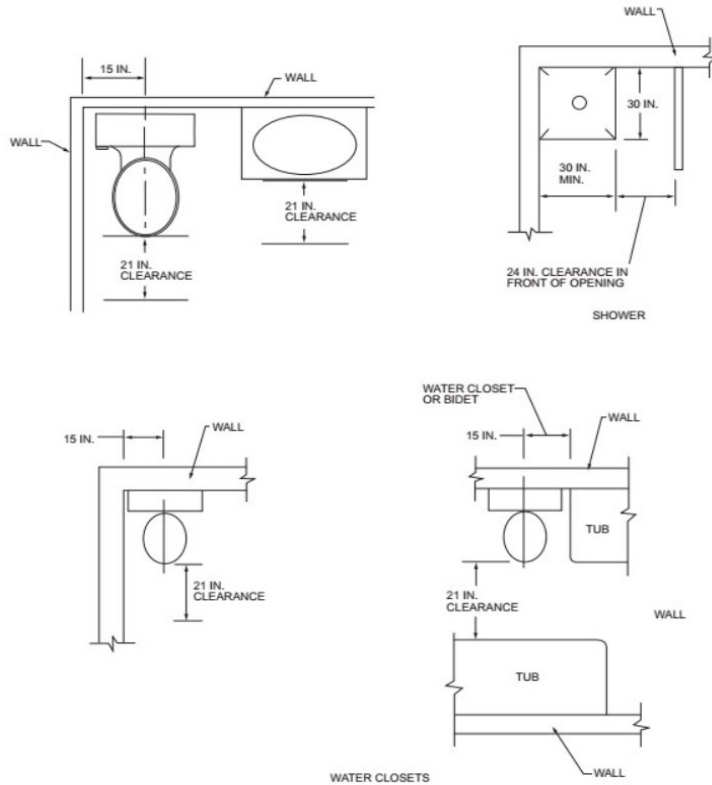

FIGURE R307.1 MINIMUM FIXTURE CLEARANCES



Centennial

C O L O R A D O

SINGLE FAMILY BASEMENT FINISH

FIRE PROTECTION OF FLOORS (FIREBLOCKING) – EXAMPLES

Fire Protection: 1/2-inch Gypsum Board Attached to Bottom of Flange

The following fire resistance design represents the default protection specified in the 2012 IRC Section R501.3, and 2015, 2018 and 2021 IRC Section R302.13.

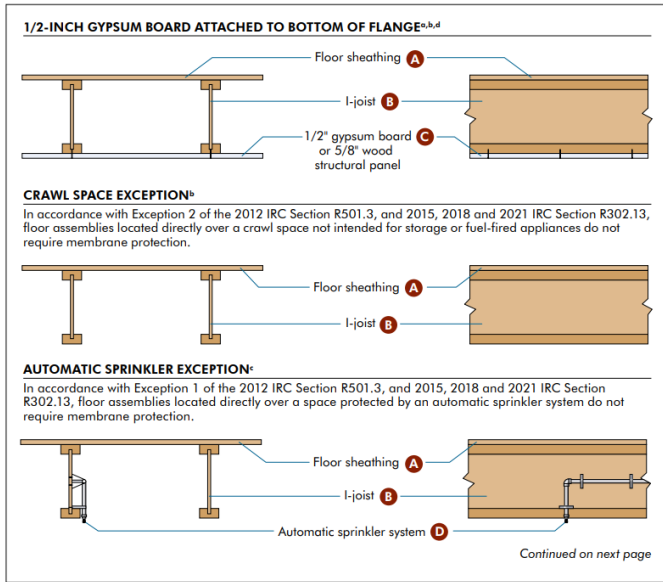

Fire Protection: Mineral Wool Insulation

The following fire resistance design is an alternative to the 2-by-10 dimensional lumber prescribed in Exception 4 of 2012 IRC Section R501.3, and 2015, 2018 and 2021 IRC Section R302.13 with demonstrated equivalent fire performance.

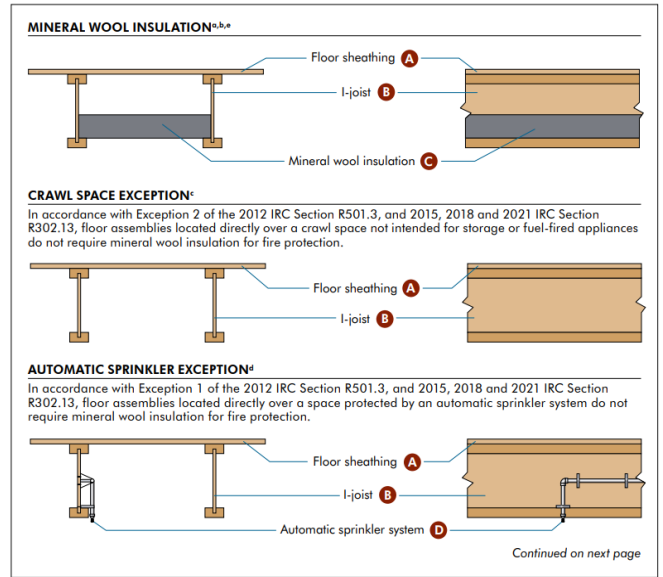

Fire Protection: Rockwool SAFE'n'Sound[®] Mineral Wool Insulation

The following fire resistance design is an alternative to the 2-by-10 dimensional lumber prescribed in Exception 4 of the 2012 IRC Section R501.3, and 2015, 2018 and 2021 IRC Section R302.13, with demonstrated equivalent fire performance.

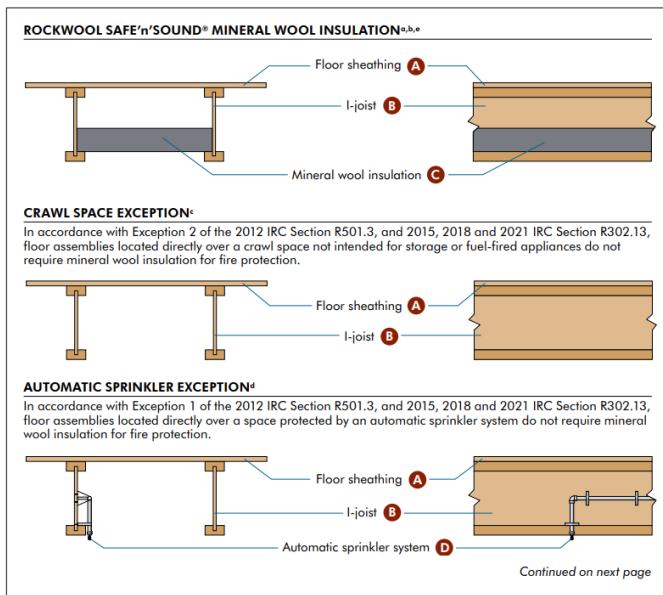



Centennial

C O L O R A D O

SINGLE FAMILY BASEMENT FINISH

FIRE PROTECTION OF FLOORS – EXAMPLES (CONTINUED)

Fire Protection: 1/2-inch Gypsum Board Attached Directly to Web

The following fire resistance design is an alternative to the 2-by-10 dimensional lumber prescribed in Exception 4 of the 2012 IRC Section R501.3, and 2015, 2018 and 2021 IRC Section R302.13 with demonstrated equivalent fire performance.

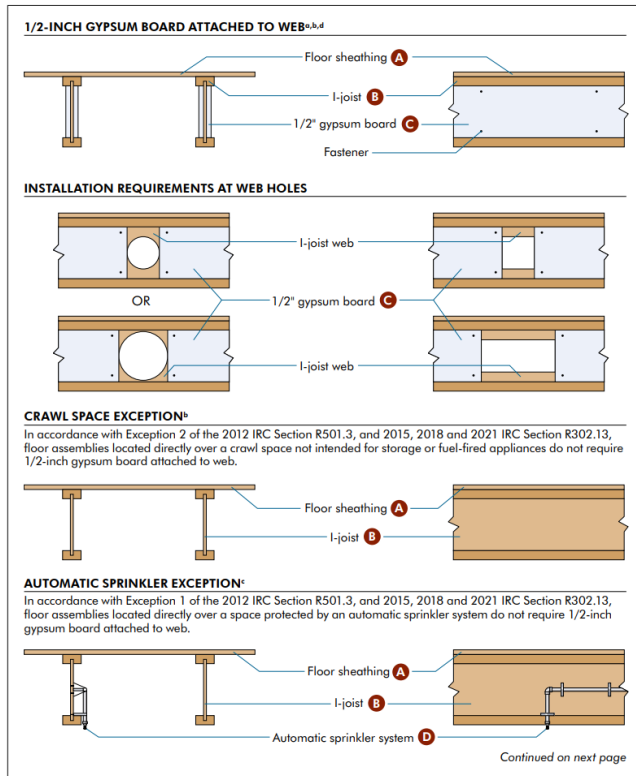

Fire Protection: 1/2-inch Gypsum Board Attached Directly to Sides of Flange

The following fire resistance design is an alternative to the 2-by-10 dimensional lumber prescribed in Exception 4 of 2012 IRC Section R501.3, and 2015, 2018 and 2021 IRC Section R302.13 with demonstrated equivalent fire performance.

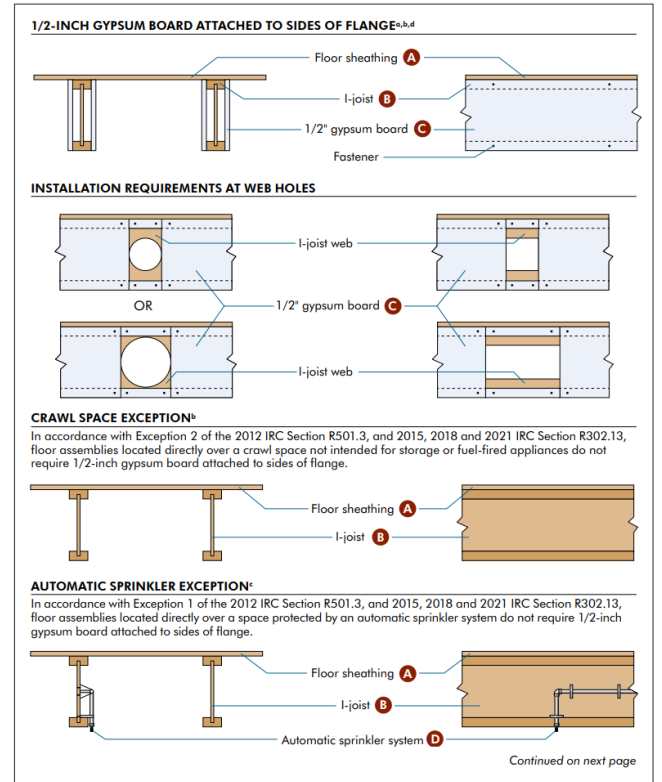



Centennial C O L O R A D O

SINGLE FAMILY BASEMENT FINISH

FIRE PROTECTION OF FLOORS (FIREBLOCKING) – EXAMPLES (CONTINUED)

Fire Protection: 1/2-inch Gypsum Board Installed on Top of the Bottom Flange

The following fire resistance design is an alternative to the 2-by-10 dimensional lumber prescribed in Exception 4 of the 2012 IRC Section R501.3, and 2015, 2018 and 2021 IRC Section R302.13 with demonstrated equivalent fire performance.

1/2-INCH GYPSUM BOARD^{a,d}

Joist spacing (in.)	Required length for gypsum boards (in.)
12	11-1/8 ± 1/8
16	15-1/8 ± 1/8
19.2	18-3/8 ± 1/8

Note:
Gypsum board lengths shown above provide at least a 1/4-inch bearing on the top of the bottom flange in each I-joint as installed. For other joist spacings, the required gypsum board lengths shall be adjusted so that the required gypsum board lengths are determined based on a full bearing on the flange at one end of the joist spacing, while maintaining at least a 1/4-inch bearing at the other end. If double joists are used, the required gypsum board lengths shall be reduced from the table above by a length equal to the flange width.

CRAWL SPACE EXCEPTION^b
In accordance with Exception 2 of the 2012 IRC Section R501.3, and 2015, 2018 and 2021 IRC Section R302.13, floor assemblies located directly over a crawl space not intended for storage or fuel-fired appliances do not require gypsum board for fire protection.

AUTOMATIC SPRINKLER EXCEPTION^c
In accordance with Exception 1 of the 2012 IRC Section R501.3, and 2015, 2018 and 2021 IRC Section R302.13, floor assemblies located directly over a space protected by an automatic sprinkler system do not require gypsum board for fire protection.

Continued on next page

Fire Protection: 5/8-inch Gypsum Board Installed on Top of the Bottom Flange

The following fire resistance design is an alternative to the 2-by-10 dimensional lumber prescribed in Exception 4 of the 2012 IRC Section R501.3, and 2015, 2018 and 2021 IRC Section R302.13 with demonstrated equivalent fire performance.

5/8-INCH GYPSUM BOARD^{a,d}

Joist spacing (in.)	Required length for gypsum boards (in.)
12	11-1/8 ± 1/8
16	15-1/8 ± 1/8
19.2	18-3/8 ± 1/8
24	23-1/8 ± 1/8

Note:
Gypsum board lengths shown above provide at least a 1/4-inch bearing on the top of the bottom flange in each I-joint as installed. For other joist spacings, the required gypsum board lengths shall be adjusted so that the required gypsum board lengths are determined based on a full bearing on the flange at one end of the joist spacing, while maintaining at least a 1/4-inch bearing at the other end. If double joists are used, the required gypsum board lengths shall be reduced from the table above by a length equal to the flange width.

CRAWL SPACE EXCEPTION^b
In accordance with Exception 2 of the 2012 IRC Section R501.3, and 2015, 2018 and 2021 IRC Section R302.13, floor assemblies located directly over a crawl space not intended for storage or fuel-fired appliances do not require gypsum board for fire protection.

AUTOMATIC SPRINKLER EXCEPTION^c
In accordance with Exception 1 of the 2012 IRC Section R501.3, and 2015, 2018 and 2021 IRC Section R302.13, floor assemblies located directly over a space protected by an automatic sprinkler system do not require gypsum board for fire protection.

Continued on next page



Centennial

C O L O R A D O

SINGLE FAMILY BASEMENT FINISH

JOB SITE ADDRESS: _____

Draw floor plan below:



SINGLE FAMILY BASEMENT FINISH

BASEMENT FINISH REQUIREMENTS

1. Ceiling Heights

Finished ceiling height in existing basements shall not be less than 6'-8" with a minimum ceiling height of 6'-4" under obstructions such as beams and ductwork.

2. Emergency Escapes

Sleeping rooms must have their own egress code compliant window or exterior door in that space. Emergency escape windows with a sill height below grade must be provided with an egress window well. For egress window and window-well requirements see attached Items II and III of these guides.

3. Smoke Detectors

A smoke detector is required in a basement in close proximity to the start of the stairs. If the finished basement contains a sleeping room, a smoke detector must be installed on the ceiling or wall in that room and in the hallway or area immediately outside of the room. Added smoke detectors can be battery powered and are not required to be hardwired. When one or more sleeping rooms are added or created in the existing residence, the entire dwelling unit shall be provided with smoke detectors located and installed as required for new dwelling units.

4. Fuel Burning Appliances

Furnaces and water heaters cannot be located in or accessed through a bedroom or bathroom unless the appliances are of the direct vent type. If the furnace and water heater are being enclosed, adequate combustion air must be provided for these appliances to operate properly. For maintenance purposes, a minimum of 30" clear working space is required to be provided in front of the furnace and water heater. Maintenance or removal of each appliance must be possible without removing permanent construction or disturbing walls, piping, valves, wiring and J-boxes.

5. Fireblocking

Fire blocking must be installed in concealed spaces of wood-furred walls at the ceiling level, at 10' intervals along the length of the wall, and at all interconnections of concealed vertical and horizontal spaces such as intersections of stud walls and soffits or dropped ceilings. **Details of fire blocking options are shown within this guide.** Fire stops may be constructed of 1/2" lumber, 3/4" plywood or OSB, 1/2" gyp board or fiberglass insulation. Manufacturer's specification documents for the fireblocking method chosen must be included with the project submittal.

6. Insulation

Provide R-19 wall cavity insulation or R-15 continuous insulation at the perimeter basement walls.

7. Space Under Stairs

Where access to the area under the basements stairs is provided for storage or other uses, the walls and ceiling of this enclosed space shall be protected on this inside with minimum 1/2" drywall.

8. Electrical Receptacles

- a. Receptacles shall be installed so that no point measured horizontally along the floor line of any wall space is more than 6 feet from a receptacle outlet.
- b. Hallways of 10 feet or more in length shall have at least one receptacle outlet. The hall length shall be considered the length measured along the centerline of the hall without passing through a doorway.
- c. GFCI protection shall be provided as outlined in the 2015 International Residential Code section E3902.

9. Lighting and Ventilation

Natural light and ventilation are required for all finished portions of the basement. This is typically accomplished

through an operable window or door. Where this cannot be achieved, mechanical ventilation and artificial will be required (see ROOM PLANNING REQUIREMENTS table within this document).

SINGLE FAMILY BASEMENT FINISH

